

interference resistant, ruggedized



PORTABLE ATTENUATION MEASUREMENT SYSTEM COMMERCIAL (PAMS-C)

Features

- MEASURES PATH LOSS, SIGNAL STRENGTH, SHIELDING EFFECTIVENESS
- 864-936MHz
- PATH LOSS ACCURACY: +/- 1 dB TYP.
- RECEIVER RANGE: 0 TO -120 dBm
- TRANSMITTER POWER: -30 TO +30 dBm
- SYNTHESIZED: 1 MHz and 100 kHz STEP SIZE
- MICROPROCESSOR CONTROLLED



Description

PAMS-C is a user-friendly, microprocessor-based transmitter and receiver system that measures shielding effectiveness of RF shielded enclosures. Lightweight and compact, each unit measures approximately 12" x 5" x 5" and weighs 5.5 lbs., making PAMS-C ideally suited to field measurement tasks. Rugged construction ensures instrument survivability in a field test environment.

PAMS-C incorporates a self-calibrating microprocessor-based architecture that provides for ease of use. It requires only minimal operator instruction for error-free operation. Its backlit LCD output displays shielding effectiveness, battery status, and other operating parameters.

PAMS-C allows the user to set a minimum shield level threshold. While sniffing around the enclosure, a tone will be heard in the headphones should the shield level drop below the threshold.

A USB interface is included on both the transmitter and receiver. This allows for serial control of selected functions and parameters. The PAMS-C receiver also includes a Spectrum Monitor mode, which displays ambient RF signals present within the test environment.

The PAMS-C receiver and transmitter are synthesized, with a minimum tuning step size of 100 kHz. Both units are battery powered, and can be operated in an AC mode when connected to the external battery charger. Normal battery operation time is 5 hours for the receiver, and 2 hours for the transmitter. "REFLEX" rapid charge control recharges batteries in 90 minutes without the memory effects normally associated with NiCd cells.

The receiver provides accurate level detection for signals in the range of -120 dBm to 0 dBm. Typical accuracy is +/-1.0 dB. An internal limiter provides protection to the receiver in the unlikely event that the receiver and transmitter are connected together. The receiver has a DC bias voltage on the connector, which may be used to power an external device such as a switch. Proper care should be exercised when connecting any device which may be susceptible to damage due to the DC voltage present.

The transmitter provides a maximum output power of +30 dBm (1 watt). Output power can be adjusted in 10 dB steps down to -30 dBm. Internal ALC circuitry maintains output level accuracy. The output of the transmitter is fully protected against damage.

The transmitter, receiver, batteries, 2 portable antennas, power packs, manual and a rugged transit case are included in the PAMS-C system.

interference resistant, ruggedized

PORTABLE ATTENUATION MEASUREMENT SYSTEM COMMERCIAL (PAMS-C)

Specifications

Note: All specifications guaranteed at 25°C unless otherwise indicated.

PAMS-C Receiver

Frequency Band:	864-936 MHz
Tuning Step Size:	1 MHz and 100 kHz
Operating Modes:	Signal Strength, Shield Level, Spectrum Monitor
IF Bandwidth:	20 kHz nominal
1 st IF:	90 MHz
2 nd IF:	455 kHz
RF Input Connector:	BNC female
RF Input Impedance:	50 ohms nominal
Input Preselection:	80 MHz 1 dB bandwidth
Signal Level Relative Accuracy:	+/- 1.0 dB (-120 dBm to 0 dBm)
Absolute Level Accuracy:	+/- 2.0 dB (-120 dBm to 0 dBm)
Maximum Safe Input Level:	+30 dBm (1 watt) minimum
Battery Operation:	5 hours minimum at full charge
Batteries:	Nickel Cadmium
AC/Charger Operation:	95-265VAC, 48-65 Hz
Charge Time:	90 minutes typical, "REFLEX" charge control
Controls:	ON/OFF/VOLUME, FREQUENCY TUNE (frequency tune) F.DIGIT (adjusts step size), THOLD (sets threshold level for go/no-go testing), LIGHT (backlights LCD display), CAL (used to provide shielding reference level normalization), MODE (scrolls through the modes)
LED Indicators:	BATTERY OVERTEMP, BATTERY CHARGE, BATTERY FAULT
LCD Displayed Functions:	Frequency, Battery Level, Mode (Signal Strength, Shield Level, Spectrum Monitor), Threshold Level Set, CAL Status, LOCK Status, Freq Adjust Status (1 MHz or 100 kHz)
Weight:	5.5 lbs nominal
Case Size:	11.7"H x 5.1"D x 4.9"W
Standard Accessories:	32 ohm headphones, battery charger/power pack, manual, 1/4 wave on top of 1/2 wave vertical monopole antenna

interference resistant, ruggedized

PORTABLE ATTENUATION MEASUREMENT SYSTEM COMMERCIAL (PAMS-C)

Specifications

PAMS-C Transmitter

Frequency Band:	864-936 MHz
Tuning Step Size:	1 MHz and 100 kHz
Maximum Output Power:	+30 dBm minimum
Output Power Control:	1, 2 or 5 dB steps from -30 to +30 dBm
Output Level Accuracy:	+/-1.0 dB maximum
Harmonics:	-60 dBc maximum
Output Impedance:	50 ohms nominal
Load VSWR:	Safe operation into infinite VSWR (isolator protected)
RF Output Connector:	BNC female
Battery Operation:	2 hours minimum at full charge
Batteries:	Nickel Cadmium
AC/Charger Operation:	95-265VAC, 48-65 Hz
Charge Time:	90 minutes typical, "REFLEX" charge control
Controls:	ON/OFF, FREQUENCY (controls both frequency tuning and power output level), F.DIGIT (selects adjustment increment for both frequency tuning and output level), LIGHT (backlights LCD display), LOCK (locks out all controls), ATTEN (toggles between 0 and 60 dB)
LED Indicators:	BATTERY OVERTEMP, BATTERY CHARGE, BATTERY FAULT
LCD Displayed Functions:	Frequency, Battery Level, Output Level, LOCK Status, Freq Adjust Status (1 MHz or 100 kHz), Power Adjust (1, 2 or 5 dB)
Weight:	5.5 pounds nominal
Case Size:	11.7"H x 5.1"D x 4.9" W
Standard Accessories:	Battery charger/AC power pack, manual, 1/4 wave vertical antenna

COMPLETE SYSTEM

Includes:	PAMS-C Receiver PAMS-C Transmitter 15V 3.4A Desktop Power Supply (2 each) Antennas (2 each) 32 ohm headphones 2M USB cable 6 ft. coaxial cable USB Drivers Operator's Manual Airtight & Watertight Heavy Duty Transit Case
Weight:	28 lbs. Nominal (all items installed in Transit Case)
Size:	21.5" L x 14.6" H x 8.1" D (nominal Transit Case)

Outline Drawings

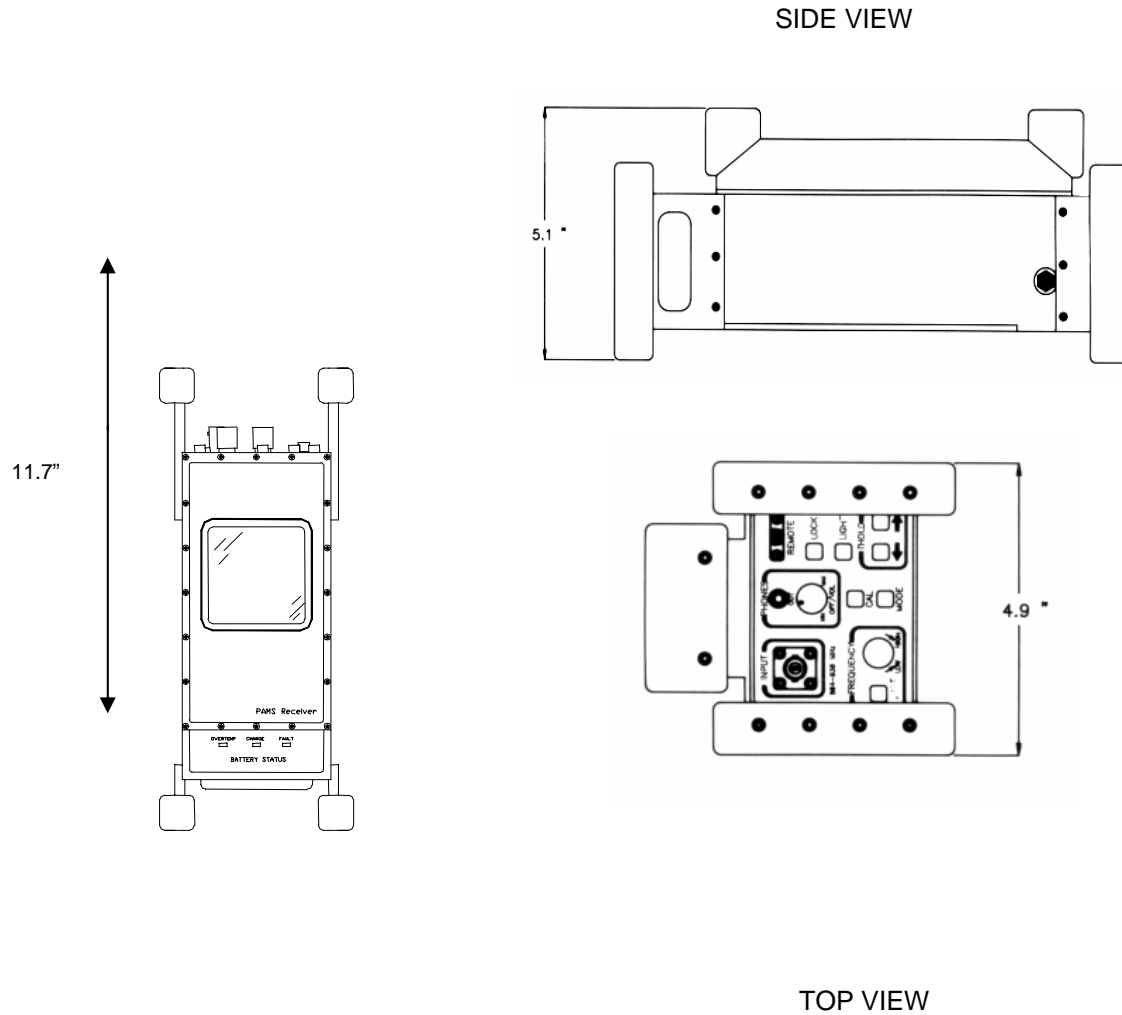

PAMS-C ORDERING INFORMATION

- PAMS-C Complete System, part number 310-010042-003
- PAMS-C Receiver Only, part number 310-010046-003
- PAMS-C Transmitter Only, part number 310-010045-003